

# TX2LR / TX2PT Series Chisel Scalers

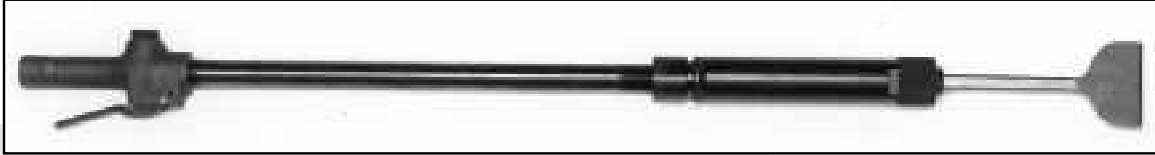

- \* **Proudly made in the U.S.A.**
- \* **World class value pricing.**
- \* **Parts availability virtually guaranteed.**
- \* **Quality equal to or better than competitively made scalers.**
- \* **Texas Pneumatic parts are more reasonably priced for lower cost maintenance during the life of the tool.**

### Tool Applications: Long Reach Scaler

- **Tile and non-skid removal**
- **Grease and paint removal**
- **Glue and resin removal**
- **Barnacle and heavy scale removal**

**2**

### Push Throttle Scaler

- **For use in foundry casting cleaning**

*This tool hits twice as hard as a regular scaler. It has a 2" stroke on the piston compared to 1-1/4" on the TX1B.*

SPECIFICATIONS:							
MODEL #	STROKE	LENGTH	WEIGHT	BORE	INLET	MINIMUM HOSE SIZE	CFM CONS.
TX2LRCS	2"	48" or 60"	14 lbs.	15/16"	1/2"	1/2"	10-12
TX2PTCS	2"	17" with chisel	6 lbs.	15/16"	1/4"	3/8"	10-12

**This tool hits twice as hard as a regular scaler. It has a 2" stroke on the piston compared to 1-1/4" on the TX-B.**

### Chisels Available for TX2:

MODEL #	DESCRIPTION
TX-20000	3"W X 7-1/2" L FLAT CHISEL (TX2LR)
TX-20029	3/4"W X 5-1/2"L FLAT CHISEL (TX2LR)
TX-20030	1-3/8"W X 5"L FLAT CHISEL (TX2LR)
TX-20031	1-3/8"W X 5"L SPOON CHISEL (TX2LR)

### Blade & Holder: NEW WIDE SCRAPER BLADES

MODEL #	DESCRIPTION
TX-20100	Blade Holder only
TX-20104	4" Width with Holder
TX-20108	8" Width with Holder
TX-20112	12" Width with Holder

See  
Schematic  
Next 2 Pages

# TX2LR / TX2PT Series

## TX2LR / TX2PT Chisel Scalers Heavy Hitter Long Reach Scalers

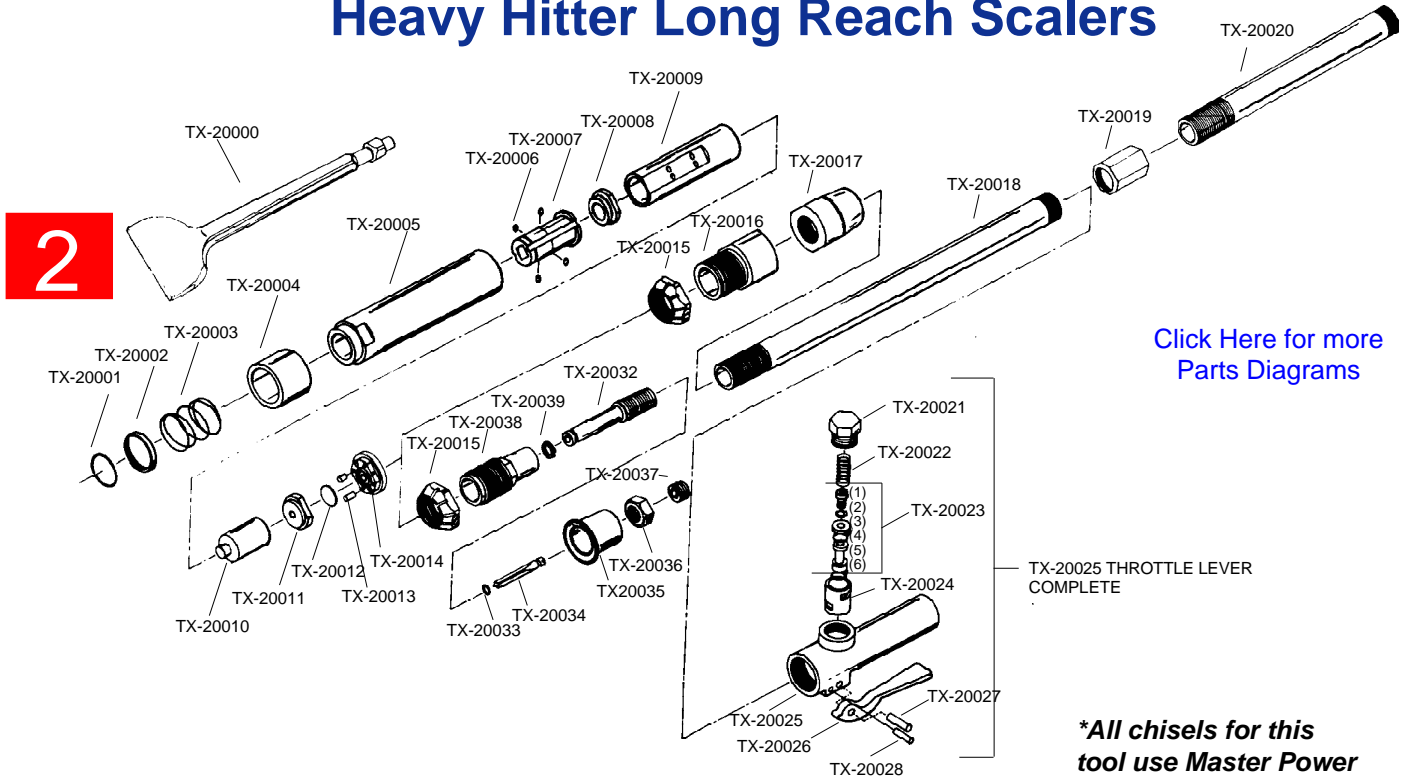

### Part List

Part #	Description
TX-20000	3" WIDE MS SHANK 7" LONG CHISEL
TX-20001	RETAINER CLIP
TX-20002	RETAINER WASHER
TX-20003	RETAINER SPRING
TX-20004	RETAINER
TX-20005	BARREL
TX-20006	5/16" STEEL BALLS (4)
TX-20007	TOOL NOSE
TX-20008	SLEEVE NOSE
TX-20009	LINER
TX-20010	PISTON
TX-20011	LOWER VALVE BLOCK
TX-20012	FLUTTER VALVE
TX-20013	DOWEL PINS 1/8 X 7/16" (2)
TX-20014	UPPER VALVE BLOCK
TX-20015	BACKHEAD LOCK RING
TX-20016	BACKHEAD BLOCK
TX-20017	BACKHEAD LOCKING PIPE NUT
TX-20018	2' PIPE EXTENSION
TX-20019	EXTENSION COUPLING
TX-20020	1' PIPE EXTENSION
TX-20021	THROTTLE VALVE CAP
TX-20022	THROTTLE VALVE SPRING
TX-20023	THROTTLE VALVE ASSEMBLY
TX-20023	CONSISTING OF:
	(1) SCREW
	(2) LOCKWASHER
	(3) TV CAP
	(4) O RING FACE
	(5) TV BODY
	(6) O RING FOR STEM
TX-20024	THROTTLE VALVE BUSHING
TX-20025	LIVE HANDLE COMPLETE
TX-20026	THROTTLE LEVER
TX-20027	STOP PIN
TX-20028	LEVER PIN
	<b>PUSH TYPE THROTTLE ASSEMBLY</b>
TX-20015	BACKHEAD LOCK RING
TX-20038	PUSH TYPE BACKHEAD
TX-20039	C CLIP RETAINER
TX-20032	THROTTLE VALVE CASING
TX-20033	O RING
TX-20034	THROTTLE VALVE
TX-20035	CONTROL VALVE HANDLE
TX-20036	LOCKING NUT
TX-20037	VALVE RETAINER
	<b>Chisels Available</b>
<b>MODEL #</b>	<b>DESCRIPTION</b>
TX-20000	3"W X 7-1/2"L FLAT CHISEL (TX2LR)
TX-20029	3/4"W X 5-1/2"L FLAT CHISEL (TX2LR)
TX-20030	1-3/8"W X 5"L FLAT CHISEL (TX2LR)
TX-20031	1-3/8"W X 5"L SPOON CHISEL (TX2LR)

TX2LR-RK  
 Repair Kit

TX-20001  
 TX-20002  
 TX-20003  
 TX-20006  
 TX-20010  
 TX-20012  
 TX-20013  
 TX-20014  
 TX-20015  
 TX-20016  
 TX-20022  
 TX-20023  
 TX-20028

# TX2LR / TX2PT Series

## Chisel for Long Reach Scaler

2

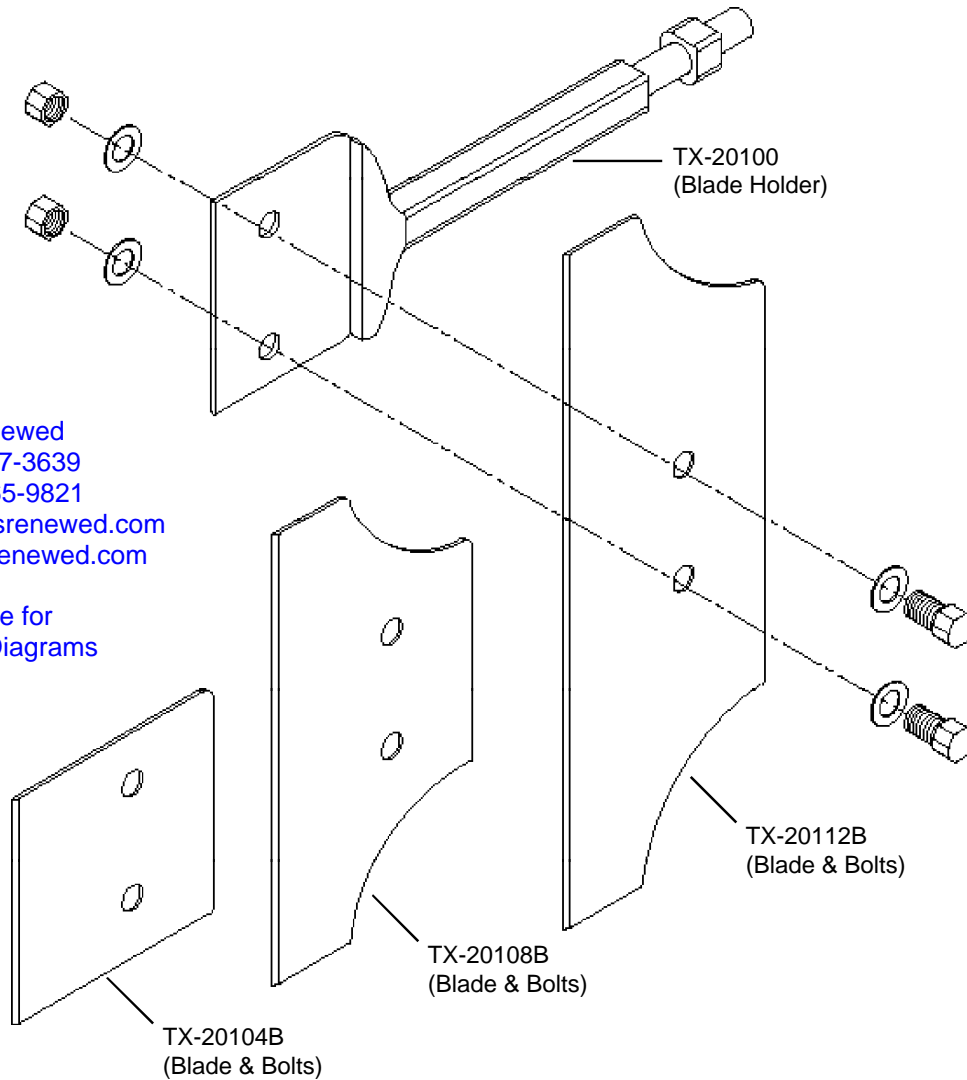

Tools Renewed  
 Tel: 800-247-3639  
 Fax: 860-665-9821  
 Email: sales@toolsrenewed.com  
 Web: www.toolsrenewed.com

[Click Here for  
 More Parts Diagrams](#)

### Part List

PART #	DESCRIPTION
<b>COMPLETE SETS</b>	
TX-20104	4" SCRAPER CHISEL
TX-20108	8" SCRAPER CHISEL
TX-20112	12" SCRAPER CHISEL