

**INGERSOLL-RAND,**  
**DRILLING EQUIPMENT**

Rock Drill Division  
 Roanoke, VA 24019

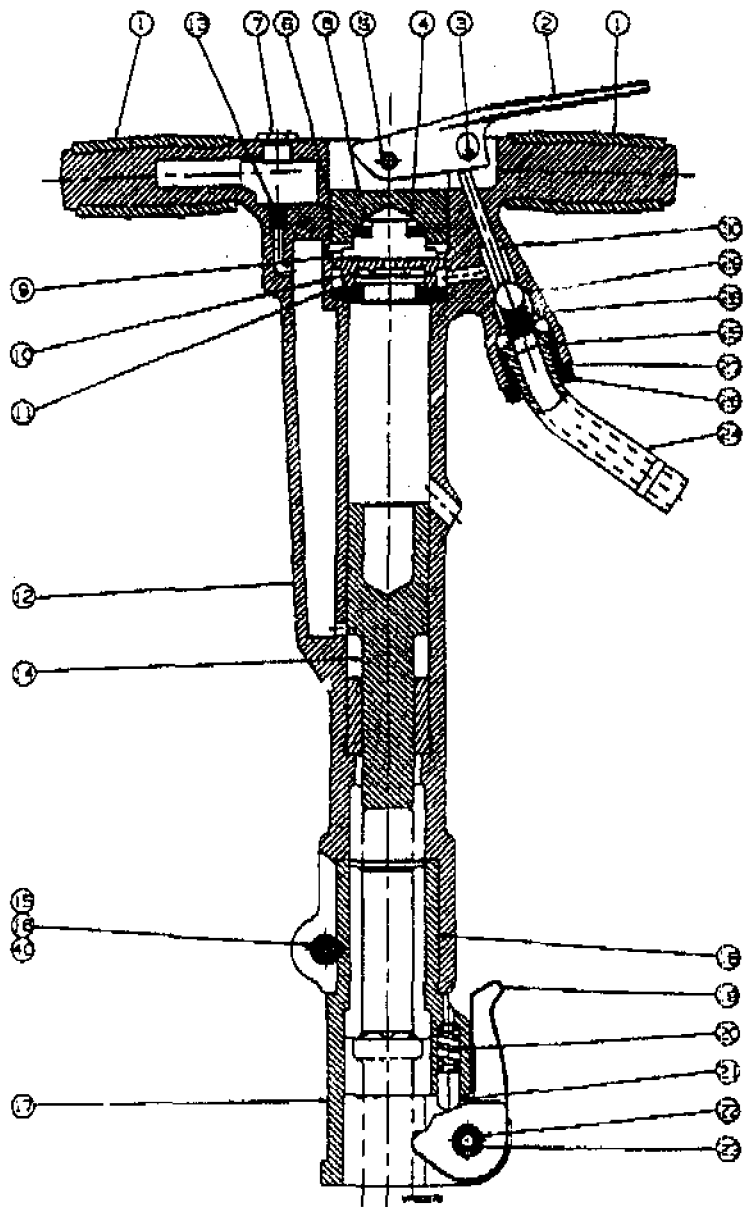

PB60A PAVING BREAKER

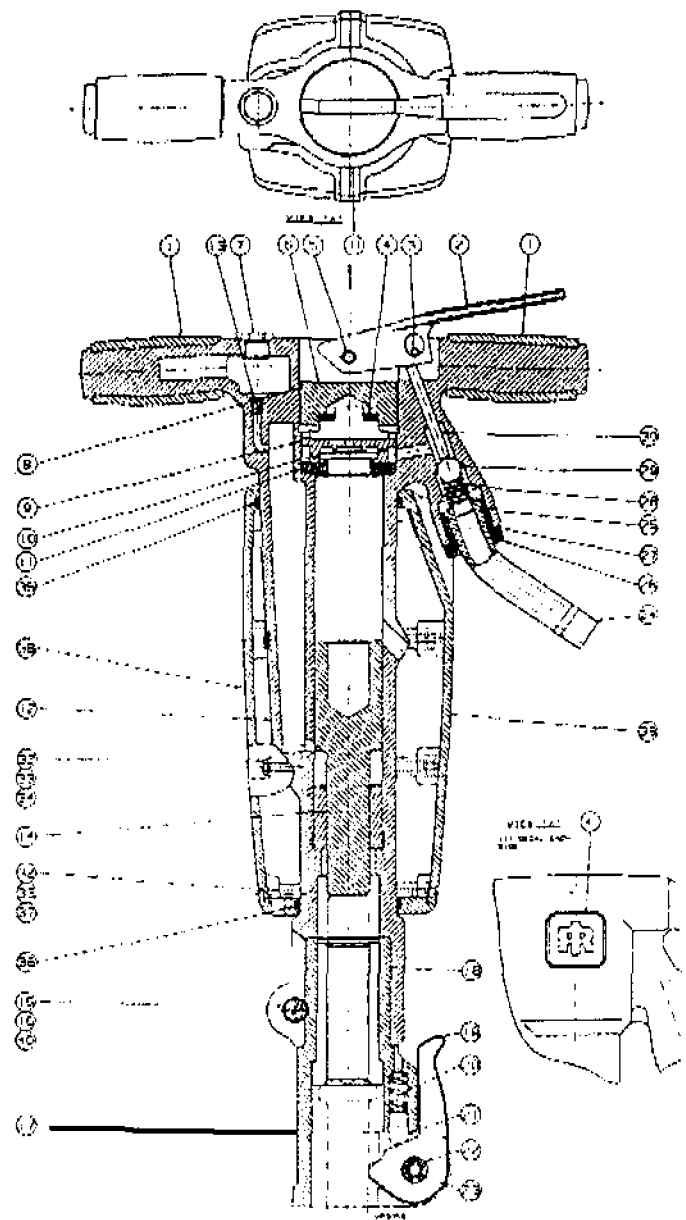

PB60AS PAVING BREAKER

**GENERAL INFORMATION**

The PB60A & PB60AS Paving Breakers are mediumweight tools that provide maximum performance at minimum cost. They are designed for general paving breaker work where a medium-weight, easy-handling breaker is necessary. With its two-piece design, the paving breakers are easier to assemble and disassemble.

**STANDARD EQUIPMENT:**

Each standard paving breaker is a complete unit ready to be put into service with proper lubrication.

There are no extra parts or special fittings required.

The standard paving breakers have a fronthead bushing that accommodates [(51306987, a 1-1/4 in. Hex x 6 in. lg (32 mm Hex. x 152 mm lg)] paving breaker shank.

**OPTIONAL FRONTHEAD:**

The following frontheads are available on special order:

- a. Fronthead for 1-1/8 in Hex. x 6 in. long (28mm Hex. x 152mm long) paving breaker shank.

## ORDERING INSTRUCTIONS

When ordering spare or replacement parts, please specify:

1. The NAME of each part as listed.
2. The PART NUMBER as listed or stamped on the part.
3. The SERIAL NUMBER of the machine.

DO NOT use illustration numbers when ordering spare or replacement parts. To save time send all orders for parts to the nearest branch office or agent. IF IT IS NECESSARY TO SEND ANY PART OF THIS MACHINE TO THE FACTORY, INQUIRE AT OUR NEAREST BRANCH OFFICE OR AGENT FOR SPECIAL INSTRUCTIONS. PRODUCT IMPROVEMENT IS A CONTINUING GOAL AT INGERSOLL-RAND. DESIGN AND SPECIFICATIONS ARE SUBJECT TO CHANGE WITHOUT NOTICE OR OBLIGATION.

REF NO.	PART NO.	PART NO.	NAME OF PART parts indented under an item are included with that item	Q T Y	RECOMMENDED SPARES		
					CLASS		
					1 Min.	2 Av.	3 Max.
	<b>PB60A-STD (51305246)</b>	<b>PB60AS-STD (51364099)</b>	<b>BREAKER, PAVING (CONSISTS OF FOLLOWING)</b>				
1	51307320	X	SLEEVE, HANDLE -----	2	-	2	4
2	51282480	X	LEVER, THROTTLE -----	1	-	-	1
3	95074100	X	PIN, ROLL -----	1	1	1	1
4	51307288	X	WASHER -----	3	3	3	3
5	95246062	X	PIN, ROLL -----	1	1	1	1
6	51237782	X	PLUG, HOUSING -----	1	-	-	1
7	51370203	X	PLUG -----	1	1	1	1
8	95086336	X	O-RING -----	1	-	1	1
9	51237741	X	CHEST, VALVE -----	1	-	-	1
10	60720515	X	VALVE -----	1	-	-	1
11	51237774	X	COVER, VALVE -----	1	-	-	1
12	51305274	X	HOUSING -----	1	-	-	1
13	51378552	X	ASSEMBLY, FILTER -----	1	-	1	1
14	51237733	X	PISTON -----	1	-	1	1
15	51356947	X	BOLT -----	1	1	1	1
16	95227112	X	NUT -----	1	1	1	1
	51307361	X	ASSEMBLY, FRONTHEAD ----- [For 1-1/4 in. Hex. x 6 in. long (32 mm Hex. x 152 mm long) Paving Breaker Shank]	1	-	-	1
17	51306769	X	FRONTHEAD -----	1	-	-	1
18	51306967	X	BUSHING, FRONTHEAD -----	1	-	1	1
19	51365120	X	LEVER, STEEL RETAINING -----	1	-	1	1
20	60018579	X	SPRING -----	1	-	1	1
21	60019728	X	PLUNGER, STL RET. LEVER -----	1	-	1	1
22	51307619	X	PIN, OUTER ROLL -----	1	1	1	1
23	51307627	X	PIN, INNER ROLL -----	1	1	1	1
24	51361863	X	NIPPLE, BENT SWIVEL -----	1	-	-	1
25	95086161	X	O-RING -----	1	1	1	1
26	51361798	X	CAP, AIR CONNECTION -----	1	-	-	1
27	95086112	X	O-RING -----	1	1	1	1
28	50250539	X	SPRING -----	1	1	1	1
29	60720572	X	BALL -----	1	1	1	1
30	95651477	X	PIN -----	1	1	1	1
31	51300077	X	DECAL -----	2	-	-	-

(Continued)

REF NO.	PART NO.	PART NO.	NAME OF PART Parts indented under an item are included with that item	QTY	RECOMMENDED SPARES		
					CLASS		
					1 Min.	2 Av.	3 Max.
	PB60A	PB60AS	<b>BREAKER, PAVING</b> (continued)				
† 32		95064655	WASHER -----	16			
† 33		95467924	NUT -----	8			
† 34		95838959	BOLT -----	8			
† 35		95087185	O-RING -----	1	1	1	1
† 36		95087086	O-RING -----	1	1	1	1
† 37		95838926	BOLT -----	2			
† 38		51360220	MUFFLER, RIGHT SIDE -----	1			
† 39		51360212	MUFFLER, LEFT SIDE -----	1			
40	51369171	x	WASHER -----	1			
			<b>OPTIONAL EQUIPMENT</b> (FURNISHED ONLY WHEN SPECIALLY ORDERED)				
	51307379	x	ASSEMBLY, FRONTHEAD (OPTIONAL) (For 1-1/8 in. Hex. x 6 in. long (26mm Hex. x 152mm long) & Paving Breaker Shank)	1	-	-	1
17	51306769	x	.FRONTHEAD -----	1	-	-	1
18	51307387	x	.BUSHING, FRONTHEAD -----	1	-	1	1
** 19	51365120	x	.LEVER, STEEL RETAINING -----	1	-	1	1
** 20	50019579	x	.SPRING -----	1	-	1	1
** 21	50019728	x	.PLUNGER, STL RET LEVER -----	1	-	1	1
** 22	51307619	x	.PIN, OUTER ROLL -----	1	1	1	1
** 23	51307627	x	.PIN, INNER ROLL -----	1	1	1	1
			<b>ACCESSORIES</b> (FURNISHED ONLY WHEN SPECIALLY ORDERED)				
	51371201	x	TUNE-UP KIT -----	1			
	51358281	x	STEEL RETAINER KIT -----	1			
	51366169	x	MUFFLER KIT -----	1			
	51378701	x	ROCK DRILL OIL (LIGHT) -----	1 GAL			
	51378693	x	ROCK DRILL OIL (MEDIUM) -----	1 GAL			
	51378784	x	ROCK DRILL OIL (HEAVY) -----	1 GAL			
	03579927	x	LUBRICATOR -----	1			